

SolarStop™ 80

Electric Fence Energizer

Read full instructions before use!

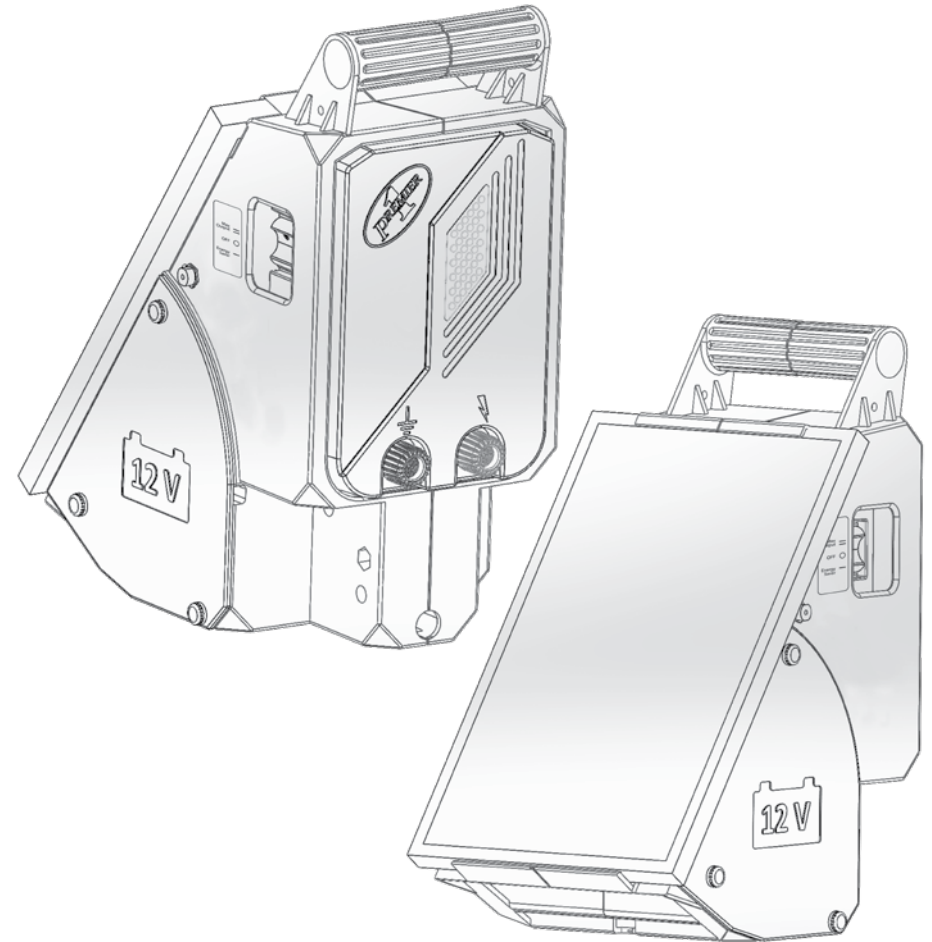

premier1supplies.com

2031 300th Street • Washington, IA 52353
800-282-6631 • 319-653-7622



premier1supplies.com

2031 300th Street • Washington, IA 52353
800-282-6631 • 319-653-7622

ENERGIZER COMPONENTS & LAYOUT

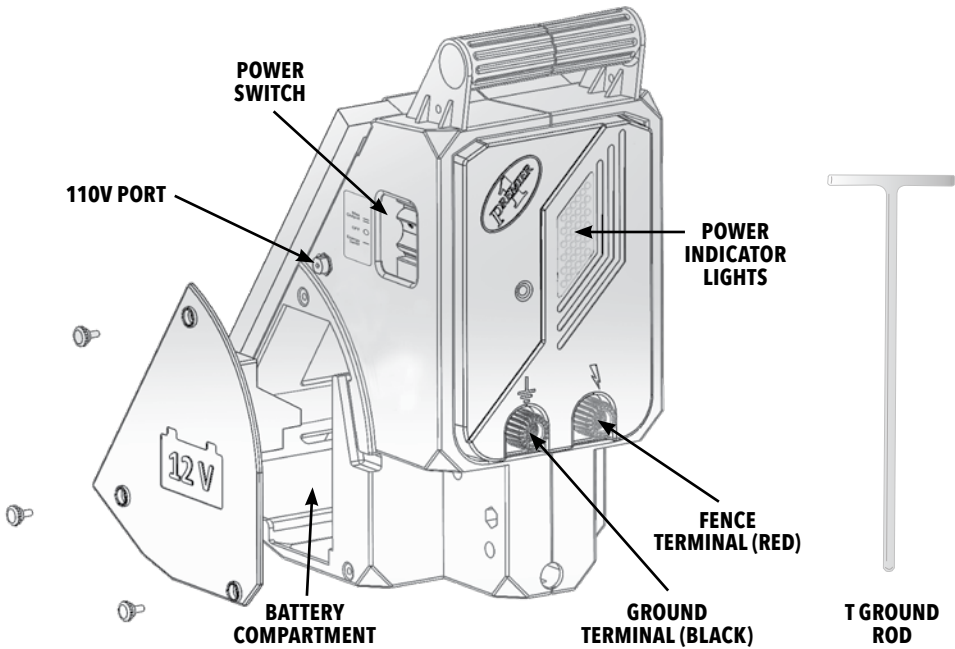

WIRING HARNESS



12V 12 AMP BATTERY



110V BATTERY RECHARGER/POWER SUPPLY ADAPTER



DIGITAL TESTER FOR FENCES AND BATTERIES

MOUNTING STAKE (Optional, sold separately #280150)

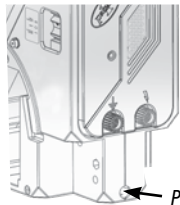
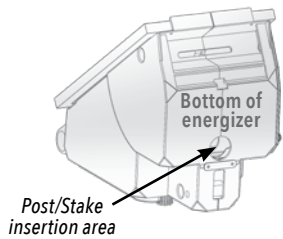

SAFETY GUIDELINES FOR ELECTRIC ANIMAL FENCES

To Reduce Risk & Liability

Are electric fences a serious safety risk to humans?

Because touching an electric fence is painful and the voltages are high, most assume that the risks from an energized fence must also be high.

That's a myth. Consider that millions of people throughout the world are "exposed" to millions of miles of electric fences every day—**yet there is less than one death or serious injury per year worldwide—and the fence is often not the cause.**

Compare that to the number of annual injuries and deaths that occur from exposure to tractors, skid loaders, PTO shafts, balers, mowers, combines, bulls, stallions, etc. This is not to suggest that there is no risk at all. There is, indeed, a small level of risk. And with risk, there is also liability.

To reduce the risk...

1. Be careful not to touch an energized wire with the head or spine. For reasons not fully understood, this contact point is more dangerous than contact with hands, arms, feet or legs.
2. Never approach a fence without footwear. Also, wear footwear that fully encloses the foot (not sandals). Why? Most footwear are poor conductors (rubber soles). So they reduce (by absorbing it) the energy that will pass through your body if you touch a fence with your hands or head.
3. Never energize barbed wire. Animals and humans can become entangled and repeatedly shocked—and thus die.
4. Hang warning signs on all areas and fences where children and adults may encounter electric fencing.
5. Use smaller energizers on fences located near children and untrained adults. (Most experts agree that small energizers are safer than large units as long as animal control isn't put at risk.)
6. Make the fence as visible as possible to both humans and animals. Use conductors and posts that can be seen both day and night, and against all backgrounds. That's why Premier has long advised the use of white/black conductors for contrast and visibility.
7. If possible, do not energize wires lower than 12". This allows humans who might contact a wire enough space to fall away from energized wires.
8. Build fences so all energized wires are on the **inside** of your boundary fence (less likely to be touched, and anyone who touches them without your permission is trespassing). We prefer offset internal energized wires on our perimeter fences.
9. Never connect two energizers to the same fence. It doubles the pulse frequency (**unsafe!**), not the output.
10. The shock from electric fences can panic animals (e.g. horses) and cause them to crash into fences (or people) resulting in injury to one or both. To reduce this risk:
 - a. Do not install electrified wires on feedlot fences, corral fences or around riding arenas.
 - b. Reduce the available volts and joules on fences that enclose very small areas (e.g. night pens) to lessen the likelihood of animal stress and possible panic.



What NOT to do!

- Never place your head or upper spine near an electrified wire.
- Never attempt to step over or climb through an energized fence of any kind.
- Never encourage anyone to touch an electric fence.

What TO do!

- Instruct all visitors and children to never touch electric fence.

ENERGIZER CONTROL PANELS & PORTS

Fig. 3

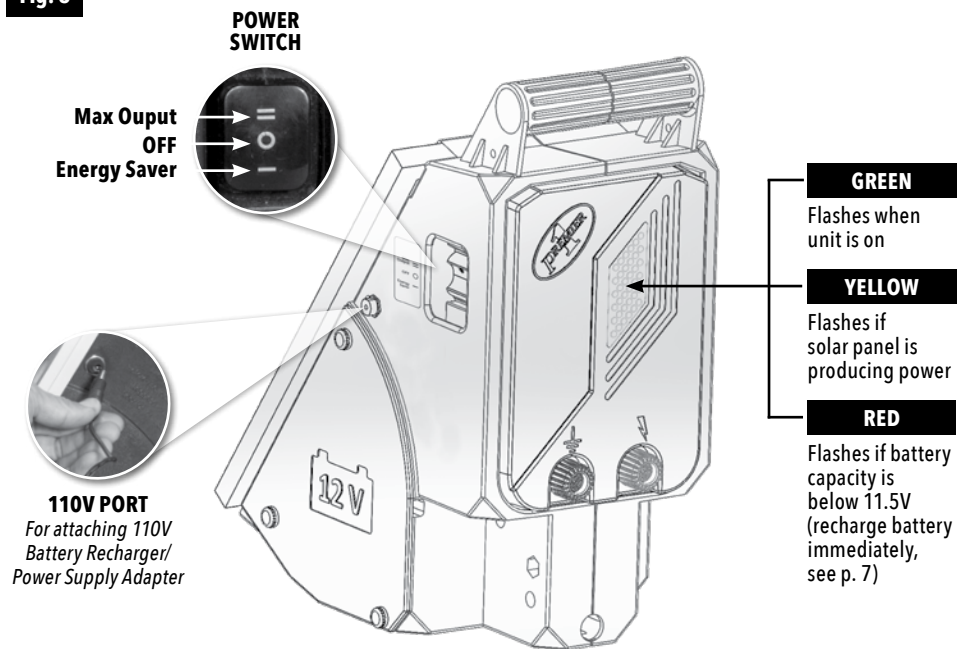

(=) Max Output , Mode II

Battery Capacity	Max. Output Energy	No Load Voltage	Impulse Interval	Current Consumption	Power Consumption
Full	0.8 joules	10,200V	1.5 seconds	64-45 mA	.832 watts
≤ to 11 volts	0.4 joules	7,300V	2 seconds	64-45 mA	.300 watts

(-) Energy Saver, Mode I

Battery Capacity	Max. Output Energy	No Load Voltage	Impulse Interval	Current Consumption	Power Consumption
Full	0.48 joules	8,000V	1.5 seconds	35-24 mA	.460 watts
≤ to 11 volts	0.4 joules	7,300V	2 seconds	35-24 mA	.300 watts

INSTALLATION AND CONNECTION

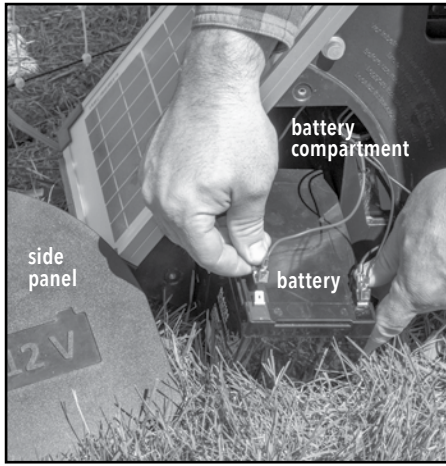

A. Open side panel (battery compartment) of energizer and connect battery. Attach black wire (- negative) to black terminal and red (+ positive) to red terminal. Replace panel.

B. With a dead blow hammer (sold separately #205015) or using your hand strength, insert into the ground, the full length of the T ground rod.

C. Attach the wiring harness to the energizer and to the fence:

1. Turn off energizer.
2. Remove the black terminal knob on the energizer.
3. Take the wire with the black clip and place the ring connector over ground terminal stud.
4. Replace knob and tighten to secure.
5. Attach the black clip to the ground rod.
6. Remove the red terminal knob on the energizer.
7. Take the wire with the orange clip and place the ring connector over fence terminal stud.
8. Replace knob and tighten to secure.
9. Attach the orange clip to the stainless steel connector at the end post of the netting or to the end of a stranded fence.

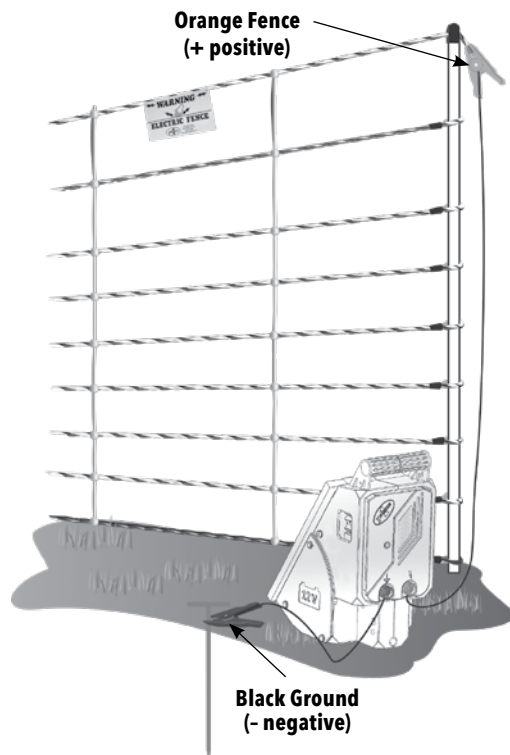
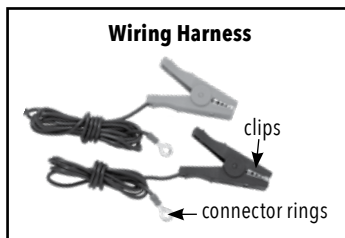

If connecting leads and electric animal fence wires are installed near an overhead power line, their height above the ground shall not exceed 6 ft.

This height applies to either side of the orthogonal projection of the outermost conductors of the power line on the ground surface, for a distance of:

- 6.6 ft for power lines operating at a nominal voltage not exceeding 1000V;
- 49 ft for power line operating at a nominal voltage exceeding 1000V

Where an electric animal fence crosses a public pathway, a non-electrified gate shall be incorporated in the electric animal fence at that point or a crossing by means of stiles shall be provided. At any such crossing, the adjacent electrified wires shall carry warning signs. In areas of public access, use an electric fence warning sign (#346000) every 33 ft to identify the electrified wire(s).

Any part of an **electric animal fence** that is installed along a public road or pathway shall be identified at frequent intervals by warning signs securely fastened to the fence posts or firmly clamped to the fence wires.

Ensure that all 110V-operated, ancillary equipment connected to the electric animal fence circuit provides a degree of isolation between the fence circuit and the supply 110V equivalent to that provided by the energizer.

Protection from the weather shall be provided for the ancillary equipment unless this equipment is certified by the manufacturer as being suitable for use outdoors, and is of a type with a minimum degree of protection.

Read for special applications

- **of electric fences in pastures:** Train livestock to electric fencing prior to entry into pastures. Allow livestock to approach an electric fence for the first time in a low stress situation.
- **of electric fences in zoos and game reserves:** The mounting of such installations may only be carried out of trained specialist, a mechanical barrier must be provided which separates the electric fence from visitors.
- **of Game Fencing:** electric fencing has been used widely throughout the world for game animals, deer, bears, elk and elephant. Electric fences are a psychological barrier and should not be considered a complete physical barrier fence. With any electric fence occasional animal penetration may occur (as with any other type of fence). It is important for game fencing to have power on the fence the same day as the fence is constructed. Animals investigating the new obstruction will be shocked and will relate the shock to the new obstruction. If no power is on the fence and animals learn to walk through the fencing system with no electric shock, this causes major problems later on since they will not relate the electric shock to the fence after the power is turned on. An electric fence is not recommended for animals under hunting pressure. For specific questions on game fencing contact your dealer.

Warning: In 1991 an accidental fatality occurred when a young child's head contacted an electrified fence while the child was crawling on wet grass. The fence was correctly installed and functioning properly. The energizer was a UL approved unit. As a result, Premier strongly advises against allowing toddlers access to any electrified fences. Also, due to this incident and others, experts now suggest that human contact by an energized wire to the head and neck may be the most dangerous point of contact. We urge all to especially avoid this kind of contact.

Read Annex BB. 1 of the International Safety Standard IEC 60335-2-76 + EN 60335-2-76 (below).

ANNEX BB. 1:

Electric animal fences and their ancillary equipment shall be installed, operated and maintained in a manner that minimizes danger to persons, animals or their surroundings.

WARNING: Do not touch the fence with head, mouth, neck or torso. Do not climb over, through or under a multi-wire electric fence. Use a gate or a specially designed crossing point. **Electric animal fence constructions** that are likely to lead to the entanglement of animals or persons shall be avoided.

An **electric animal fence** shall not be supplied from two separate **energizers** or from independent **fence circuits** of the same **energizer**.

For any two separate **electric animal fences**, each supplied from a separate **energizer** independently timed, the distance between the wires of the two electric animal fences shall be at least 8.3 ft. If this gap is to be closed, this shall be effected by means of electrically non conductive material or an isolated metal barrier. Barbed wire or razor wire shall not be electrified by an **energizer**.

A non-electrified fence incorporating barbed wire or razor wire may be used to support one or more off-set electrified wires of an **electric animal fence**. The supporting devices for the electrified wires shall be constructed so as to ensure that these wires are positioned at a minimum distance of 6" from the vertical plane of the non-electrified wires. The barbed wire and razor wire shall be grounded at regular intervals.

Follow the energizer manufacturer's recommendations regarding earthing.

A distance of at least 33 ft should be maintained between the **energizer earth electrode** and any other with the grounding system connected parts such as the power supply system protective ground or the telecommunication system ground.

- **Connecting leads that are run inside buildings** shall be effectively insulated from the grounded structural parts of the building. This may be achieved by using insulated high voltage cable. Use this lead-out cable in buildings and where soil could corrode exposed galvanized wire. Never use household electrical cable: it is made for a maximum of 600 volts and will leak electricity.
- **Connecting leads that are run underground** shall be run in conduit of insulating material or else insulated high voltage cable shall be used. Care must be taken to avoid damage to the connecting leads due to the effects of animal hooves or tractor wheels sinking into the ground.
- **Connecting leads shall not be installed in the same conduit as the mains supply wiring,** communication cables or data cables.
- **Connecting leads and electric animal fence wires shall not cross above overhead power or communication lines.** Crossings with overhead power lines shall be avoided wherever possible. If such a crossing cannot be avoided it shall be made underneath the power line and as nearly as possible at right angles to it. If connecting leads and electric animal fence wires are installed near an overhead power line, the clearances shall not be less than those shown in Table BB1.

Table BB 1
Minimum clearances from power line for electrical animal fences

POWER LINE VOLTAGE (V)	CLEARANCE
≤ 1,000V	10 ft
> 1,000V and ≤ 33,000V	13 ft
> 33,000V	27 ft



D. Position energizer so that the solar panel faces south in full sun.

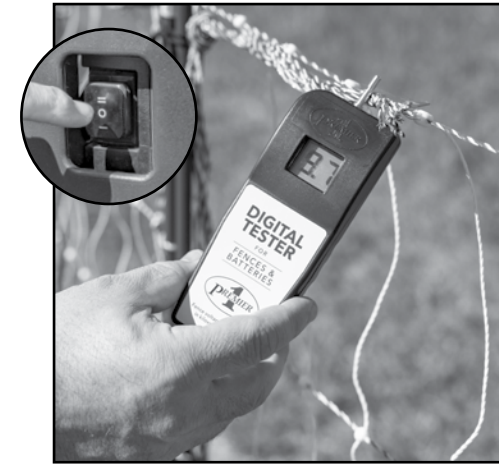

E. Turn on energizer and check the voltage at the end of the fence with a fence tester to ensure the fence is properly electrified before introducing it to animals. **Minimum of 3000V at the end of the fence.**

MAXIMUM FENCE LINE LENGTH

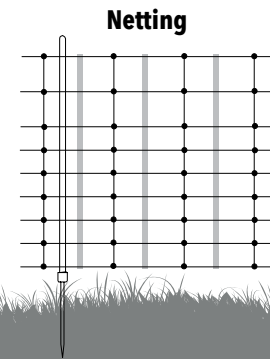

3-6 rolls
Depending on soil conditions and vegetation

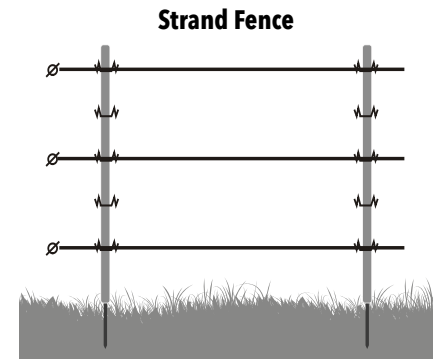

Cattle: 1-1/2 miles of 3 strand fence
Sheep: 1/2 mile of 5-7 strand fence

IMPORTANT:

Make sure the battery is measuring 12.6–13.4 volts. If it's not, recharge the battery (see p. 7). Placing the energizer in shade will not keep the battery fully charged. Make sure the panel faces south in full sun.

OPTIMAL SOLAR ORIENTATION AND PLACEMENT



1. POSITION THE ENERGIZER SO THAT THE SOLAR PANEL FACES DUE SOUTH

This will allow the panel to receive the maximum amount of sunlight possible even during the low-light days of winter. Consider the sun's movement throughout the day and avoid placing the unit where it may be covered by shadows from trees, bushes or tall grass.



2. REGULARLY REMOVE ALL DEBRIS FROM SOLAR PANEL

This includes grass clippings, dust (especially on gravel roads), leaves and snow as this will reduce the solar panel's ability to recharge the battery.

Use 110V Recharger (see p. 2) or solar panel to fully charge battery before use.
Battery may have discharged during storage and transport.

WARRANTY

2-year warranty for energizers and solar panels covers lightning damage and defective parts or workmanship. Should an energizer fail, we will replace the unit, bill you for the cost to do so, then reimburse you for warranted unit after we have examined the failed unit. Misuse and flood damage are not covered.

30-day warranty for all batteries.

B. SAFETY GUIDELINES ELECTRIC ANIMAL FENCES

PART 1: PRINCIPLES AND LIMITATIONS OF ELECTRIC FENCING FOR ANIMALS

An electric fence consists of an energizer and a connected fence where the energizer feeds electric impulses into the fence. The electric animal fence represents a "psychological barrier" for the animals; it keeps animals inside or outside a certain area, it can also be used to train a certain behavior (e.g. cow trainer in the stable).

No electric or mechanical fence can guarantee a 100% effective solution in protecting or containing your animals. The effectiveness of an electric fence may vary upon the unique local conditions within which the fence is installed. A suitable combination of products together with competent installation will ensure the best results. On occasion a determined animal may overcome the most rigid of mechanical fences or the most comprehensive electric fence system. **For this reason the seller gives no assurance that the fence system is 100% safe against escape.** A well installed electric fence can offer a high level of security when compared to a mechanical fence, as the psychological barrier, an electric shock, can deter the animal from finding a way to circumnavigate the fence. Electric fences will also offer far greater level of flexibility.

PART 2: WARNING! READ BEFORE USING

- This energizer is not intended for use by persons (including children) with reduced physical, sensory or mental capabilities, or lack of experience and knowledge, unless they have been given supervision or instruction concerning use of the energizer by a person responsible for their safety. Children should be supervised to ensure that they do not play with the energizer.
- Never touch an electric fence wire with your head, mouth, neck or torso. Never allow anyone else to do so. Instruct all visitors and children to never do so. Do not climb over, through or under a multi-wire electric fence. Use a gate or a specially designed crossing point.
- To avoid any risks with the head, mouth, neck or torso contacts, use low-output energizers or lower the output of a stronger energizer on fences near children and untrained adults. Lower the energizer output by placing a 500 ohm resistor between the fence terminal and the fence. Adding the resistor may require changing the fence design to reduce weed contact (which will further lower the output).
- Keep a distance of at least 8.3 ft with the electric fence to all metallic parts (i.e. to water pipes).
- Do not place combustible materials near the fence or energizer connections. In times of extreme fire risk, disconnect energizer.
- If there is a danger of flood, the energizer must be turned off and removed from the area.
- Help to avoid any misuse of the energizer by:
 - Reading the instructions
 - Securing the energizer against un-allowed access (e.g. anti-theft or anti-children equipment) if the location makes this necessary
- Check your local ordinance for specific regulations.
- Read Annex BB.1 of the International Safety Standard IEC 60335-2-76 + EN 60335-2-76 (page 12).

DUTY TO THE PUBLIC:

Safe electric fence construction is covered on pp. 4-7.

Electric fence can be hazardous when there is a risk of entrapment or entanglement, or other hazards exist. Serious injury or death may result. Take all steps to avoid the risk of entrapment or entanglement. Fasten warning signs to electric fence posts or wires at frequent intervals along any public roads or pathways. Incorporate a non-electrified gate or stile where an electric animal fence crosses a public pathway and fasten warning signs to fence posts or wires adjacent to the crossing.

A. FUNCTION AND MAINTENANCE

WORKING PRINCIPLE:

The solar panel (see p. 6) produces electric current when exposed to usable sunlight. The fence energizer requires a constant current, day and night. Thus the panel current is stored in the battery which delivers the energizer current. The solar panel might not always be capable of recharging the battery, especially in dark, gray and foggy months (i.e. October -February).

Tip: Recharge the battery externally as needed (see p. 7).

STORAGE, RECHARGE, MOUNTING AND CONNECTIONS:

When not in use, ensure the battery stays charged. You can charge the battery in the sun or with the included 110V charging unit. Do not overcharge the battery. A fully charged 12V battery will test between 12.6 and 13.4V. When the energizer is not being used, store the unit indoors at room temperature. Batteries don't work well when they're left discharged, or at a low charge, for long periods of time. Periodically, recharge the battery so that it does not discharge below 60%.

WINTER TIME BATTERY PROTOCOL:

When not in use, ensure the battery stays above a charge of 12.2V. Lead acid batteries don't work well when they're left discharged, or at a low charge, for long periods of time. Periodically recharge the battery in the sun or with the included 110V charging unit. Stop charging when the battery measure 12.6 - 13.4 volts.

GROUNDING:

For a faultless operation and to obtain the optimal output, good ground is essential. Therefore grounding must be made in a moist location. An additional or deeper ground rod may improve grounding, especially in dry, arid regions. The distance between the system earth (grounding) and other earth systems (e.g. telephone, mains power, anti-lightning or other earth systems of another energizers) should be at least 30 ft.



CAUTION:

The energizer should only be opened or repaired by qualified personnel, to reduce the risk of electric shock!

TO RECHARGE THE BATTERY

Move the energizer (indoors without fence and ground connection "wiring harness"). Attach the **110V Battery Recharger/Power Supply Adapter (#371040-US)** into the port on the side of the energizer. With the energizer off, recharge the battery until the battery measures between 12.6 and 13.4 volts.

The battery should be allowed to relax 30 minutes after being taken off the recharger before testing. Use a **Digital Tester for Fences & Batteries (#200010)** or a Multimeter to test the battery.

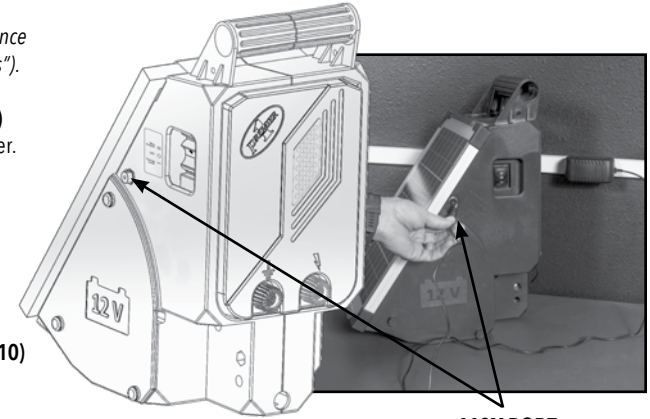

Charge to 14V, the LED changes from RED to GREEN.
Red light indicates the recharger is charging the battery.
Green indicates the battery is charged.

110V PORT
Battery Recharger/
Power Supply Adapter

CONNECTING ENERGIZER TO 110V

For 110V operation of the energizer, plug the 110V adapter directly into an indoor 110V outlet and then use an insulated leadout wire (#164207) to connect from the energizer fence terminal to the fence.
Note: Only use the 110V Recharger/Power Supply Adapter supplied or a genuine SolarStop 80 replacement part (#371040-US). Do not use an extension cord.

DO NOT use a 110V Power Supply if it has gotten wet.

IMPORTANT: INDOOR DRY LOCATIONS ONLY!

The 110V adapter must be installed in a room protected from moisture.

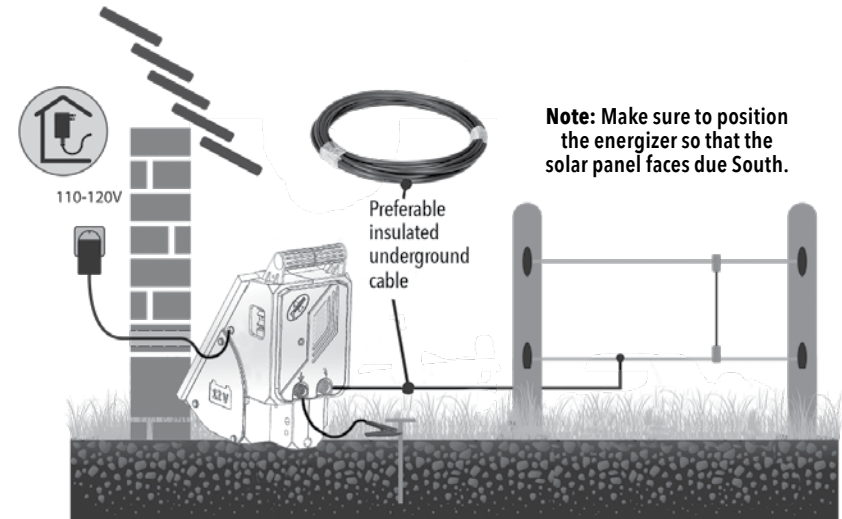

SPARE PARTS

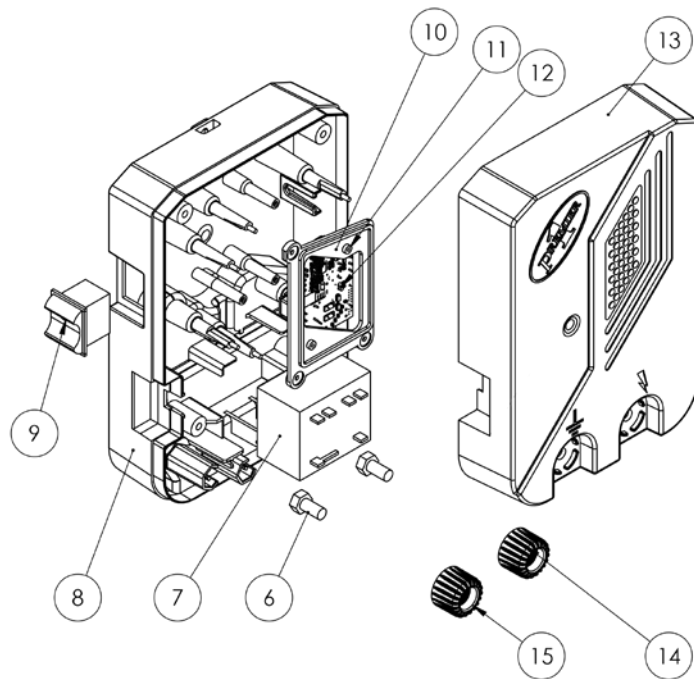
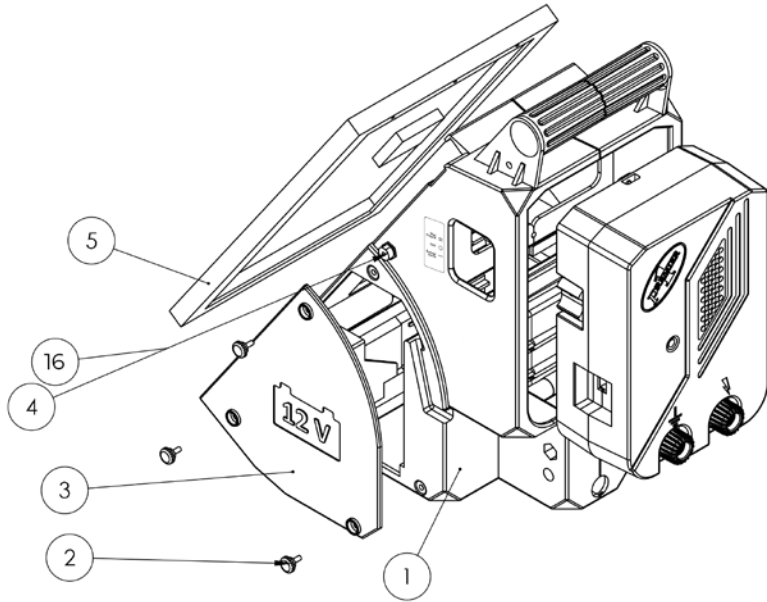

SPARE PARTS OR REPLACEMENT PARTS

NO.	ITEM #	DESCRIPTION	QTY
1	280034	Basic Casing (black)	1
2	261633	Knurled Screw M 4x10 (black)	1
3	280035	Battery Lid (black)	1
4	281322	Recharging Socket for 110V Battery Recharger/Power Supply	1
5	281321	10W Solar Panel	1
6	434056	Connection Screw M 8x16mm	1
7	E268851	Transformer	1
8	269359	Bottom Casing (black)	1
9	266820	Switch 1-0-2	1
10	280148	Holder for Circuit Board	1
11	434172	Screw for Holder / Circuit Board	1
12	E281164	Circuit Board	1
13	280174	Upper Casing (blue)	1
14	268862	Knurled Nut (red) Fence	1
15	268861	Knurled Nut (black) Earth	1
16	268317	Plastic cap for recharging socket	1
REPLACEMENT PARTS			
17	151220	T Ground Rod, 18"	1
18	130800	Wiring Harness	1
19	121600	Sealed Lead Acid 12V 12amp Battery	1
20	371040-US	110V Battery Recharger / Power Supply Adapter, 1.5A	1
21	200010	Digital Tester for Fences & Batteries	1

